

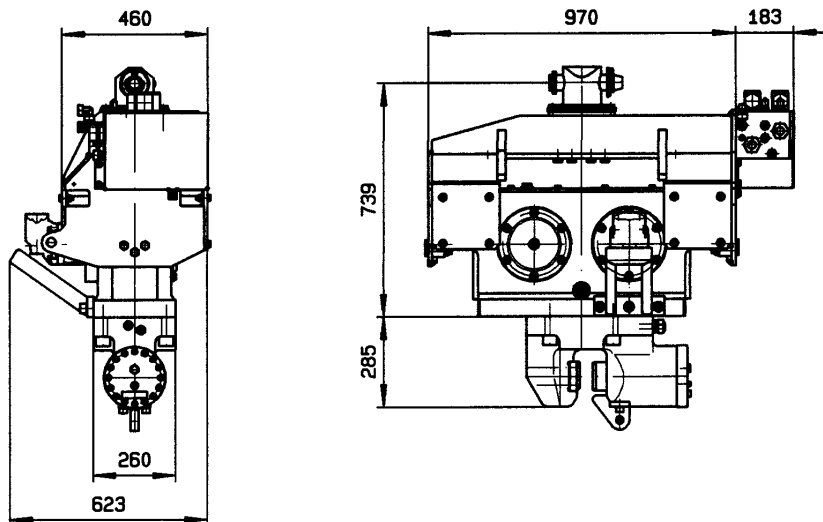

Müller-Vibrator	TA 0509/1
MS-2 / 3 HFB	Dat.: 24.09.2001 Name: Honig



TECHNISCHE DATEN / TECHNICAL DATA
Vibrator

			MS-2 HFB	MS-3 HFB
Fliehkraft max.	/ centrifugal force max.	kN	245	304
Exzentermoment	/ eccentric moment	kgm	2,2	3
Drehzahl max.	/ speed max.	min ⁻¹	3185	3000
Zugkraft max.	/ line pull max.	kN	60	60
Druckkraft max.	/ push down max.	kN	40	40
Gewicht *	/ weight *	kg	815	830
Gewicht (dynamisch) *	/ weight (dynamic) *	kg	570	585
Hydraulik:				
Schluckvolumen	/ flow rate	l/min	95	120
Betriebsdruck max.	/ working pressure max.	bar	350	350

*mit Spannzange

*with clamping device

Subject to Technical modifications

Distributed in Australia & New Zealand by ThyssenKrupp Steelcom <small>A company of ThyssenKrupp Services</small>		ThyssenKrupp
PO Box 840 North Sydney NSW 2059 Australia T: + 61 2 9954 9166 Sales + 61 2 4966 0688 F: + 61 2 9955 4298 enquiries@steelcom.com.au www.steelcom.com.au	PO Box 51254 Pakuranga Auckland 2140 New Zealand T: + 64 9 576 3977 F: + 64 9 576 3978 afenn@steelcomnz.co.nz www.steelcomnz.co.nz	