

New 6PHFV and 8PHFV excavator mounted

The new PHFV range has been specifically developed to optimise pile driving using hydraulic excavators.

- **8PHFV:** On 25 to 40t excavators
- **6PHFV:** On 18 to 30t excavators

A new generation of the variable moment technology

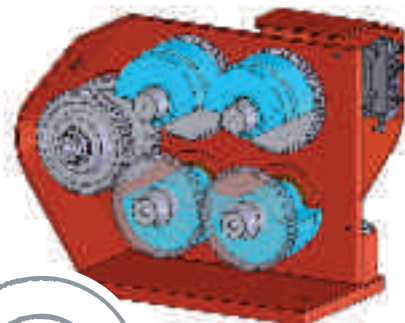

The new HFV patent consists of a new compact and simplified design of the variable moment system. It features a rotary jack enclosed in a new housing mechanism that protects it from the multiple forces generated by the system. Thus, significantly improving reliability and simplifying maintenance.



Outstandingly compact

Conscious of the increasing need for compact equipment to work in tight spaces often found in urban projects, PTC has designed an outstandingly compact Vibrodriver which has an eccentric moment of 8 m.kg with a total weight of only 1.67 t (clamp included).

- improves job efficiency
- reduces driving time
- allows to drive even heavier profiles

Ideal to work in sensitive areas (city centre, historical and ancient urban areas) thanks to its strict control of vibratory emissions

New hydraulic kit



The interface between the excavator and the 8PHFV is made by a single rock breaker circuit, which supplies the entire Vibrodriver. Furthermore, thanks to an electric remote control, it can be easily operated from the excavator cabin.

New clamp Agriplex 60t: 2 working positions

The new Agriplex 60t can be mounted perpendicular to the Vibrodriver (90° position), thus allowing to work almost flush against a wall (at a distance of only 25 cm).

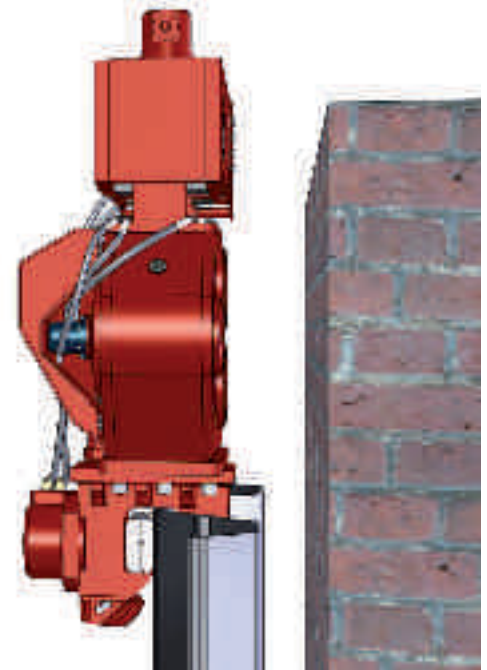

Technical specifications	Units	8PHFV	6PHFV	8HFV**
Eccentric moment	m.kg	0-8	0-6	0-8
Hydraulic power	kW / HP	110 / 149	86 / 117	113 / 153
Maximum frequency	Hz / r.p.m.	39.2 / 2350	39.2 / 2350	39.2 / 2350
Max. hydraulic flow	l/min	188	148	188
Max. centrifugal force	kN	494	370	494
Max. pull capacity	kN	120	120	120
Max. working pressure	bar	350	350	385
Vibrating weight with Agriplex 60t	kg	1239	1210	1239
Total weight with Agriplex 60t	kg	1676	1647	1667
Total weight without Agriplex 60t	kg	1411	1382	1402
Amplitude with agriplex 60t	mm	12.9	9.9	12.9
Length (L)	m	1.408	1.408	1.225
Max. width (l max)	m	0.623	0.623	0.623
Width at centre (w)	m	0.345	0.345	0.345
Height with Agriplex 60t	m	1.779	1.779	1.779
Clamping force Agriplex 60t	kN	600	600	600

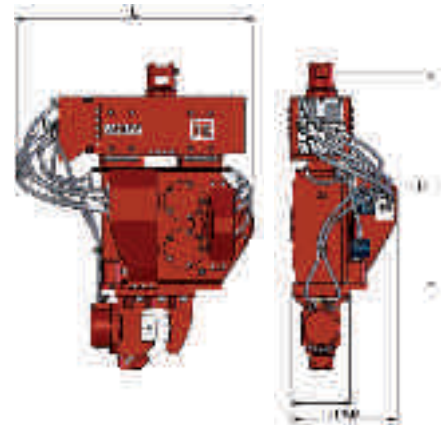

** The 8HFV is the version adapted for a crawler crane using a power pack 240D

Applications



A whole
new range
soon
available ...

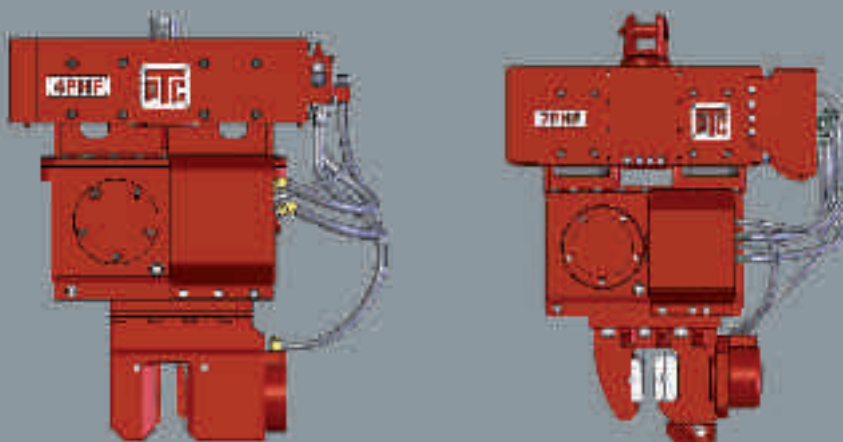

2PHF - 3PHF - 4PHF - 7PHF and 2PHFV



FAYAT GROUP

56 rue de Neuilly
93136 Noisy-le-Sec Cedex - France

Tel : +33 (0)1 49 42 72 95
Fax : +33 (0)1 48 44 00 02
E-mail : contact@ptc.fayat.com
Website : www.ptc.fayat.com