

1.0

Section product range
Design tables conforming to EAB

2.0

Section illustrations and data

3.0

Available types
Terms of delivery

4.0

Steel piles
Box piles
Steel sheet pile walls
Wide flange bearing piles
Wide flange beams
Pipe piles
Pipe pile walls
Angle walls

5.0

Special services

6.0

Anchors/anchor equipment
Driving, extracting, drilling and pressing equipment

3.0

Available types, terms of delivery

3.1	Interlock designs	Page 1
3.2	Steel grades and terms of delivery for hot-rolled sections	
3.2.1	Steel grades for hot-rolled sections	Page 2
3.2.1	Higher-strength, weldable sheet piling steels supplied to works standards	Page 2
3.2.1	Materials – Standard steel grades for PEINE sections	Page 2
3.2.2	ÜHP proof of conformity for steel sheet piles according to “Bauregelliste A”, Part 1	Page 3
3.2.3	Deviation limits and dimensional tolerances for hot-rolled sheet piles made of unalloyed steels conforming to DIN EN 10 248-2	Page 4
3.3	Steel grades and terms of delivery for cold roll formed sheet piles	
3.3.1	Steel grade for cold roll formed sheet piles conforming to DIN EN 10 249-1	Page 5
3.3.1	Deviation limits and dimensional tolerances for cold roll formed sheet piles made of unalloyed steels conforming to DIN EN 10 249-2	Page 5
3.4	Available types/handling holes and cramping/welding	
3.4.1	LARSEN sections	Page 6 to 8
3.4.2	HOESCH sections	Page 9 to 10
3.4.3	UNION straight-web sections	Page 11 to 12
3.4.4	Lightweight sections	Page 13 to 14
3.4.5	Trench sheeting sections	Page 15
3.5	Fitting the section interlocks together	
3.5.1	LARSEN	Page 16
3.5.2	HOESCH	Page 17 to 18
3.5.3	UNION straight-web sections	Page 18









3.0 Available types

Terms of delivery

3.1

Available sections, terms of delivery

Interlocks

<p>LARSSEN section Interlock design conforming to DIN EN 10248-2 and E 67 of EAU 2004</p>	
<p>LARSSEN 43, 430 Interlock design conforming to DIN EN 10248-2 and E 67 of EAU 2004</p>	
<p>HOESCH section (finger-and-socket interlock) Interlock design conforming to DIN EN 10248-2 and E 67 of EAU 2004</p>	
<p>PEINE interlock steel/ PEINE sheet piling Interlock design conforming to DIN EN 10248-2 and E 67 of EAU 2004</p>	
<p>UNION straight-web section Interlock design conforming to DIN EN 10248-2 and E 67 of EAU 2004</p>	
<p>KL lightweight section Interlock design conforming to DIN EN 10249-2</p>	

Available sections, terms of delivery

Sheet piling steel grades for hot-rolled sheet piles conforming to DIN EN 10 248-1

Steel grade	Tensile strength	Minimum yield point	Minimum elongation
	N/mm ²	N/mm ²	%
S 240 GP	340	240	26
S 270 GP	410	270	24
S 320 GP	440	320	23
S 355 GP	480	355	22
S 390 GP ¹⁾	490	390	20
S 430 GP ¹⁾	510	430	19

¹⁾ For the higher-strength sheet piling steels S 390 GP and S 430 GP, an approval certificate (Z-30. 1-7) from the building supervisory authorities dated February 28, 2005 is available.

Higher-strength weldable sheet piling steels according to works standards

Steel grade	Tensile strength	Minimum yield point	Minimum elongation
	N/mm ²	N/mm ²	%
St Sp 460	550	460	17
St Sp 500	590	500	16

Further steel grades to national and international standard available on request.

Materials – Standard steel grades for PEINER sections

Steel grades	Standard
Structural steels	EN 10025
Fine grain structural steels	EN 10113
Weather resistant steels	EN 10155
Sheet piling steels	EN 10248
Special steel grades of the PEINE Träger series	PEINE Träger material standard, minimum yield point from 355 to 460 N/mm ²
Further steel grades upon request	e. g.: BS, NF, ASTM, JIS, CSAG, GOST, UNI

All sections are available in accordance with current national and international standards and also special specifications if required.

A choice is provided in the table “Steel grades”.

3.2.2

Available sections, terms of delivery

ÜHP proof of conformity for steel sheet piles in accordance with Bauregelliste (list of relevant standards and specifications) A, Part 1

During production, a certified quality management system conforming to DIN EN ISO 9001 upholds a high standard of quality from the start of the process right through to the finished steel sheet piling.

This is an essential precondition for the demanded ÜHP proof of conformity for sheet steel piles in accordance with Bauregelliste A, Part 1.

Following inspection by the North-Rhine/Westphalian Materials Testing Office (Document No. 11 0001 0 97), HSP Hoesch Spundwand and Profil GmbH in Dortmund is entitled to conformitymark its steel sheet piles produced in accordance with DIN EN 10248.

In addition, all sections are supplied with the rolled HOESCH mark. This means it is possible to trace all approved construction products and exclude confusion with materials without conformity mark approval.

The materials flow, identification, traceability and marking of HSP products are elements of the quality assurance system built up in accordance with DIN EN ISO 9001/2000 and recertified by LRQA from January 1, 2005.



Available sections, terms of delivery

Deviation limits and dimensional tolerances for hot-rolled sheet piles made of unalloyed steels conforming to DIN EN 10 248-2

Pile width	Single piles $\pm 2\%$; double and triple piles $\pm 3\%$
Wall thicknesses of U sections	t: up to 8.5 mm = ± 0.5 mm; over 8.5 mm = $\pm 6\%$ t s: up to 8.5 mm = $- 0.5$ mm; over 8.5 mm = $- 6\%$ s ¹⁾
Wall thicknesses of Z sections and straight-web sections	t, s: up to 8.5 mm = ± 0.5 mm; over 8.5 mm = $\pm 6\%$ s, t
Height of U sections	h: up to 200 mm = ± 4 mm; over 200 mm = ± 5 mm
Height of Z sections	h: up to 200 mm = ± 5 mm; von 200 up to 300 mm = ± 6 mm; over 300 mm = ± 7 mm
Deviation from straightness	The longitudinal deviation from straightness must not exceed 0.2% of pile length.
Pile length	Sheet pile lengths are permitted to deviate by ± 200 mm from the ordered lengths.
Cut	Cut at right angles to the longitudinal axis. The total deviation between the highest and lowest points in the cutting plane, measured on a single pile along the longitudinal axis, must not exceed 2% of pile width.
Weight	The tolerance between the arithmetic weight (according to section tables) and weighed weight of the total consignment must be within $\pm 5\%$.
Section interlocks	The interlocks shall have adequate free play so that the piles can be fitted into each other and they must engage in such a manner that the in-service forces can be transmitted. The minimum interlock overlap on U and Z piles must not be less than 4 mm and on straight-web sections not less than 7 mm.

¹⁾ Normally the positive tolerance shall be at the discretion of the manufacturer. At the time of the enquiry and order, a limitation on the positive tolerance can be agreed. In this case, the following values should be chosen: + 0.5 mm for $s \leq 8.5$ mm and + 6 % s for $s > 8.5$ mm.

3.3.1

Available sections, terms of delivery

Steel grade for cold-roll formed sheet piles conforming to DIN EN 10 249-1

Steel grade	Tensile strength	Minimum yield point	Minimum elongation
	N/mm ²	N/mm ²	%
S 275 JC	410	275	22

Deviation limits and dimensional tolerances for cold-roll formed sheet piles made of unalloyed steels conforming to DIN EN 10249-2

Pile width	Single piles $\pm 2\%$, double piles $\pm 3\%$
Sheet thickness for nominal widths up to 1200 mm	from 4.00 to 5.00 mm = ± 0.24 mm; from 5.00 to 6.00 mm = ± 0.26 mm; from 6.00 to 8.00 mm = ± 0.29 mm
Sheet thickness for nominal widths from 1200 to 1500 mm	from 4.00 to 5.00 mm = ± 0.26 mm; from 5.00 to 6.00 mm = ± 0.28 mm; from 6.00 to 8.00 mm = ± 0.30 mm
Pile height	up to 200 mm pile height ± 4 mm
Deviation from straightness	The longitudinal deviation from straightness must not exceed 0.25% of pile length.
Twist	The twist must not exceed 2% of pile length, but must be no more than 100 mm.
Pile length	Sheet pile lengths are permitted to deviate by ± 50 mm from the ordered lengths.
Cut	Cut at right angles to the longitudinal axis. The total deviation between the highest and lowest points in the cutting plane, measured at right angles to the pile's longitudinal axis, must not exceed 2% of pile width.
Weight	The tolerance between the arithmetic weight (according to section tables) and weighed weight of the total consignment must be within $\pm 7\%$.

Available sections, terms of delivery

Section abbreviations



E, Ea, Eb	= single pile
D, Da, Db, Dz	= double pile
Dr, Dra, Drb	= triple pile
V	= quadruple pile

Adapter piles

To achieve fixed wall lengths, it may be necessary to fit adapter piles. The system widths of these piles are modified as required, although the width of the individual adapter pile depends on driving requirements.

Available LARSEN sections

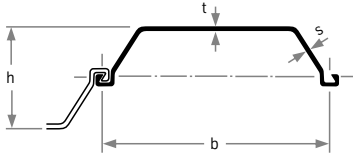
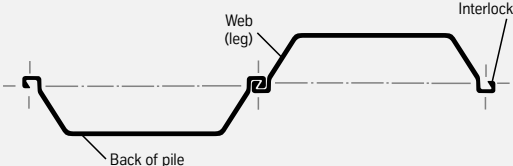
20, 600, 700 and 750 series

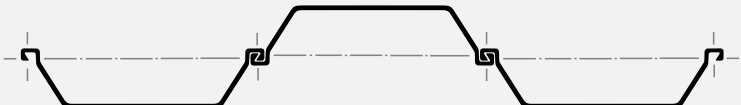
E	
D (S-shape)	
Dz	 <p>Non-standard form</p>
Dr	 <p>Triple piles of the 700 and 750 series on request</p>

3.4.1

Available sections, terms of delivery

LARSSEN 43

(Pay attention to interlock position)

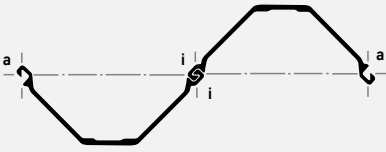
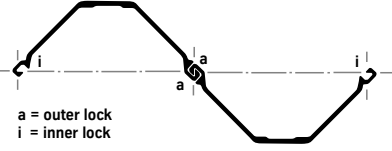
<p>E</p>	
<p>D (S-shape)</p>	
<p>Dz (Z-shape, for wall form 430 only)</p>	 <p>a = outer lock i = inner lock</p>

Triple piles on request

LARSSEN 430

(Wall form of LARSSEN 43)

V

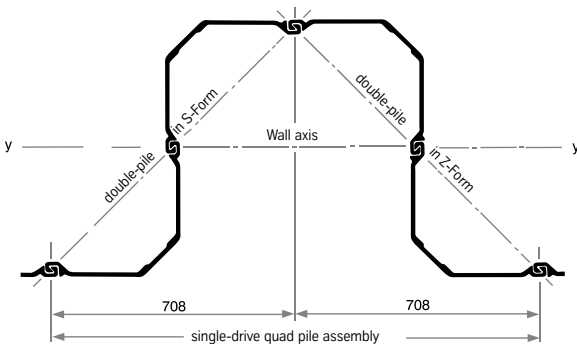

To withstand the shear forces, it is necessary to cramp the interlocks on the wall axis.

Handling holes and cramping/welding of LARSEN sections

Handling holes can be provided on request. Each pile back is then provided with a hole as indicated on the drawing. Holes can be provided at a distance of either 75 or 300 mm from the upper pile edge (to be stated when ordering).

The section moduli stated in this manual for LARSEN sections necessitate the locking of the pile interlocks, either by factory cramping, factory shearresistant welding or site welding.

The interlocks of double piles prefabricated in the factory are doublecramped at centers of approx. 0.4 m, while those of triple piles are doublecramped at 0.8 m centers. Cramps may also be spaced more closely by arrangement.

When the interlock bars are pushed in opposite directions, each cramp is capable of absorbing 75 kN after a pushing distance of 5 mm.

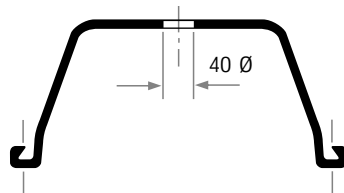
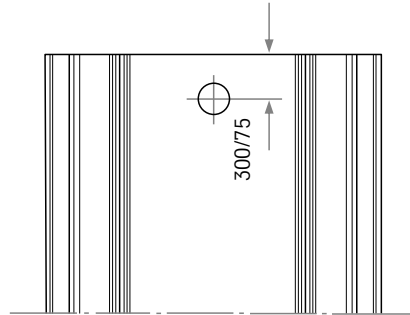

3.4.2

Available sections, terms of delivery

Available HOESCH sections

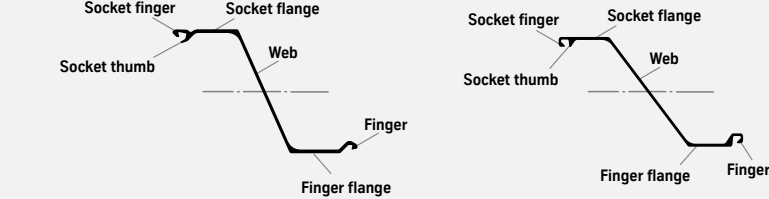
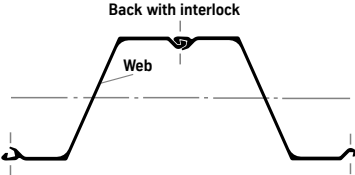
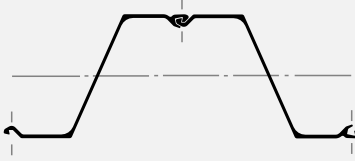
Eb	 <p>(E in b-position, web falling to the right)</p>
Da	
Db	 <p>Triple piles on request</p>

Handling holes and cramping/welding of HOESCH sections

Handling holes can be provided on request. Each pile web is then provided with a hole as indicated on the drawing. Holes can be provided at a distance of either 75 or 300 mm from the upper pile edge (to be stated when ordering). Composite piles which have been prefabricated in the factory are cramped at the interlocks on request, i.e. the interlocks are pressed together by means of a punch at regular intervals down the back of the pile.

The section moduli of HOESCH sections do not necessitate the cramping of prefabricated interlocks.

On request, cramping can be provided for transport and handling purposes. The cramping points are spaced at 2.40 meters.

Instructions for the site and construction:

- When taking up and inserting unpressed piles together, each pile must be suspended from a lifting hook.
- The position of the cramping mark should be borne in mind if the walls are visible.

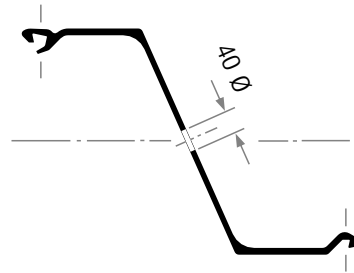
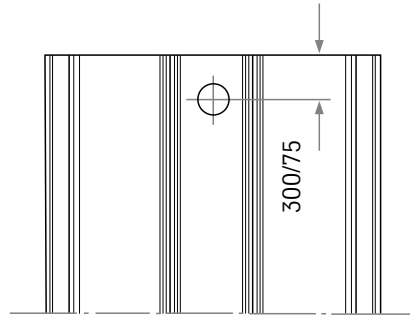

3.4.3

Available sections, terms of delivery

Available UNION straight-web sections

E

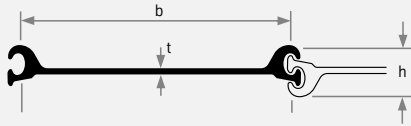

D

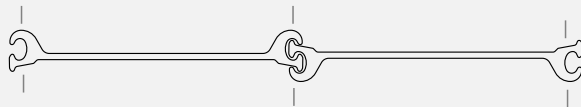
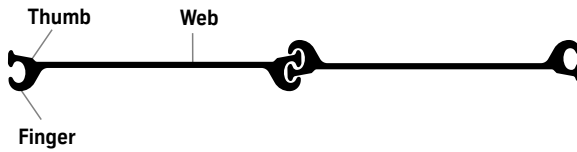

Non-standard form

Available sections, terms of delivery

Handling holes and cramping/welding of UNION straight-web sections

Handling holes are provided on request in the center of each pile web as shown in the drawing.

Holes can be provided at a distance of either 75 or 300 mm from the upper pile edge (to be stated when ordering).

The double piles of UNION straight-web sections are always supplied without cramping.

Note:

When lifting unpressed double or multiple piles on the site, each pile must be suspended from a lifting hook.

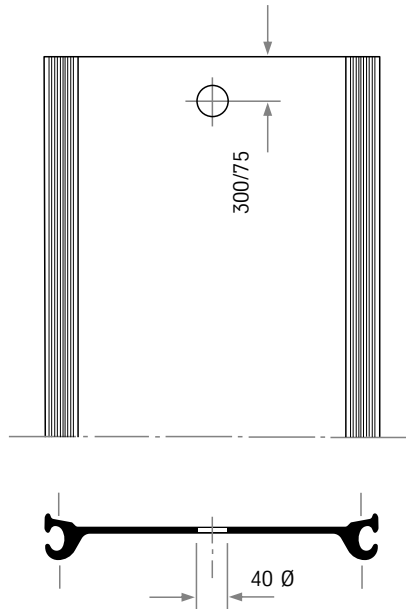

3.4.4

Available sections, terms of delivery

Available KL, TKL and HP lightweight sections

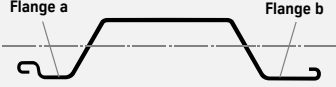
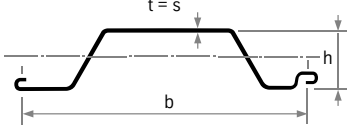
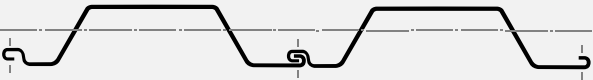
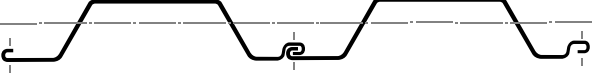
Ea	 <p>Single pile in a-position</p> <p>(Non-standard form)</p>
Eb	 <p>Single pile in b-position</p> <p>(Standard form)</p>
Da	 <p>Double piles (Da) only available by special agreement.</p>
Db	 <p>Double piles (Db) only available by special agreement.</p>

Available ZK lightweight sections

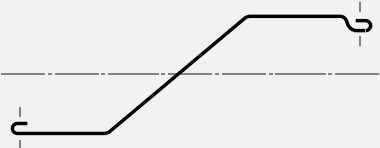
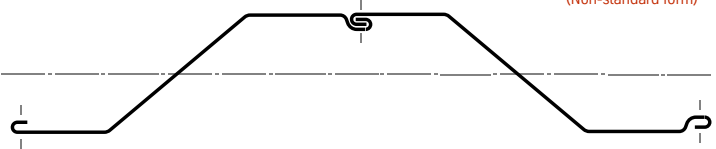
E	
D	 <p>Double piles (D) only available by special agreement. Double piles welded in the interlock on one side.</p> <p>(Non-standard form)</p>

Available sections, terms of delivery

Handling holes of KL and TKL lightweight sections and hat sections (HP)

The KL and TKL lightweight sections and HP hat sections are supplied with handling holes. The holes are applied at both ends, as shown in the figure.

View B

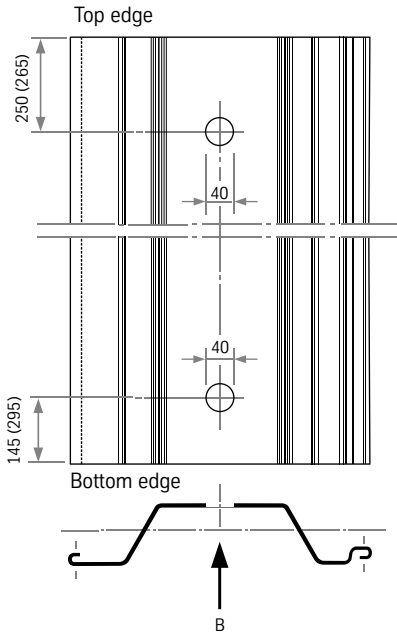

a-position

KL section hole	145 mm from top edge 250 mm from bottom edge	Non-standard form
HP and TKL section hole	265 mm from top edge 295 mm from bottom edge	Standard form

b-position

KL section hole	250 mm from top edge 145 mm from bottom edge	Standard form
HP and TKL section hole	295 mm from top edge 265 mm from bottom edge	Non-standard form

ZK lightweight section hole

ZK lightweight sections are supplied without handling holes.

Welding of ZK lightweight sections

Double piles, which we only supply by special agreement, can be welded in the interlock on one side at the top, bottom or in the middle of the pile.

The weld seam at the top and bottom is 15 cm long in each case.

Other seams are 10 cm long and welded at intervals of 1.5 m.

3.4.5

Available sections, terms of delivery

Available trench sheeting

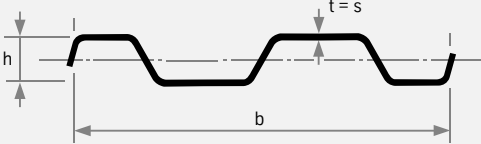
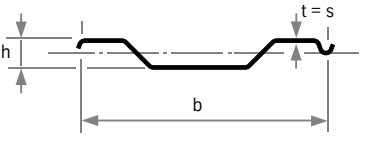
E KD VI/6 KD VI/8	
E KD 4/4 KD 4/6	

Handling holes of KD VI/6 and KD VI/8 trench sheeting

View A

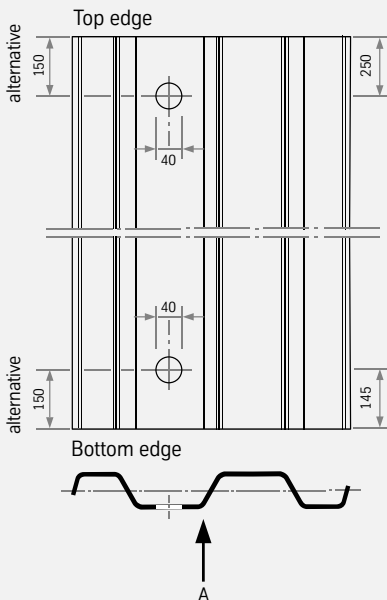

Handling holes in KD 4/4 and KD 4/6 trench sheeting

The holes are applied at both ends, as shown in the figure.

Available sections, terms of delivery

Fitting LARSEN sections together

Section	Matching the sections															
	755	703	704	600	601	602	603	604	605	606 n	607 n	22 10/10	23	24	25	43
755	<input type="checkbox"/>	<input type="checkbox"/>	<input type="checkbox"/>	<input checked="" type="checkbox"/>	<input checked="" type="checkbox"/>	<input checked="" type="checkbox"/>	<input type="checkbox"/>	<input type="checkbox"/>	<input type="checkbox"/>	<input type="checkbox"/>	<input type="checkbox"/>	<input type="checkbox"/>	<input type="checkbox"/>	<input type="checkbox"/>	<input type="checkbox"/>	<input type="checkbox"/>
703 ¹⁾	<input type="checkbox"/>	<input type="checkbox"/>	<input type="checkbox"/>	<input type="checkbox"/>	<input type="checkbox"/>	<input type="checkbox"/>	<input type="checkbox"/>	<input type="checkbox"/>	<input type="checkbox"/>	<input type="checkbox"/>	<input type="checkbox"/>	<input type="checkbox"/>	<input type="checkbox"/>	<input type="checkbox"/>	<input type="checkbox"/>	<input type="checkbox"/>
704	<input type="checkbox"/>	<input type="checkbox"/>	<input type="checkbox"/>	<input checked="" type="checkbox"/>	<input checked="" type="checkbox"/>	<input checked="" type="checkbox"/>	<input type="checkbox"/>	<input type="checkbox"/>	<input type="checkbox"/>	<input type="checkbox"/>	<input type="checkbox"/>	<input type="checkbox"/>	<input type="checkbox"/>	<input type="checkbox"/>	<input type="checkbox"/>	<input type="checkbox"/>
600 ¹⁾	<input checked="" type="checkbox"/>	<input type="checkbox"/>	<input checked="" type="checkbox"/>	<input type="checkbox"/>	<input type="checkbox"/>	<input type="checkbox"/>	<input type="checkbox"/>	<input type="checkbox"/>	<input checked="" type="checkbox"/>	<input checked="" type="checkbox"/>	<input checked="" type="checkbox"/>	<input type="checkbox"/>	<input checked="" type="checkbox"/>	<input checked="" type="checkbox"/>	<input checked="" type="checkbox"/>	<input type="checkbox"/>
601	<input checked="" type="checkbox"/>	<input type="checkbox"/>	<input checked="" type="checkbox"/>	<input type="checkbox"/>	<input type="checkbox"/>	<input type="checkbox"/>	<input type="checkbox"/>	<input type="checkbox"/>	<input checked="" type="checkbox"/>	<input checked="" type="checkbox"/>	<input checked="" type="checkbox"/>	<input type="checkbox"/>	<input checked="" type="checkbox"/>	<input checked="" type="checkbox"/>	<input checked="" type="checkbox"/>	<input type="checkbox"/>
602	<input checked="" type="checkbox"/>	<input type="checkbox"/>	<input checked="" type="checkbox"/>	<input type="checkbox"/>	<input type="checkbox"/>	<input type="checkbox"/>	<input type="checkbox"/>	<input type="checkbox"/>	<input checked="" type="checkbox"/>	<input checked="" type="checkbox"/>	<input checked="" type="checkbox"/>	<input type="checkbox"/>	<input checked="" type="checkbox"/>	<input checked="" type="checkbox"/>	<input checked="" type="checkbox"/>	<input type="checkbox"/>
603 ¹⁾	<input type="checkbox"/>	<input type="checkbox"/>	<input type="checkbox"/>	<input type="checkbox"/>	<input type="checkbox"/>	<input type="checkbox"/>	<input type="checkbox"/>	<input type="checkbox"/>	<input type="checkbox"/>	<input type="checkbox"/>	<input type="checkbox"/>	<input type="checkbox"/>	<input type="checkbox"/>	<input type="checkbox"/>	<input type="checkbox"/>	<input type="checkbox"/>
604 n	<input type="checkbox"/>	<input type="checkbox"/>	<input type="checkbox"/>	<input type="checkbox"/>	<input type="checkbox"/>	<input type="checkbox"/>	<input type="checkbox"/>	<input type="checkbox"/>	<input type="checkbox"/>	<input type="checkbox"/>	<input type="checkbox"/>	<input type="checkbox"/>	<input type="checkbox"/>	<input type="checkbox"/>	<input type="checkbox"/>	<input type="checkbox"/>
605 ¹⁾	<input type="checkbox"/>	<input type="checkbox"/>	<input type="checkbox"/>	<input checked="" type="checkbox"/>	<input checked="" type="checkbox"/>	<input checked="" type="checkbox"/>	<input type="checkbox"/>	<input type="checkbox"/>	<input type="checkbox"/>	<input type="checkbox"/>	<input type="checkbox"/>	<input type="checkbox"/>	<input type="checkbox"/>	<input type="checkbox"/>	<input type="checkbox"/>	<input type="checkbox"/>
606 n	<input type="checkbox"/>	<input type="checkbox"/>	<input type="checkbox"/>	<input checked="" type="checkbox"/>	<input checked="" type="checkbox"/>	<input checked="" type="checkbox"/>	<input type="checkbox"/>	<input type="checkbox"/>	<input type="checkbox"/>	<input type="checkbox"/>	<input type="checkbox"/>	<input type="checkbox"/>	<input type="checkbox"/>	<input type="checkbox"/>	<input type="checkbox"/>	<input type="checkbox"/>
628	<input type="checkbox"/>	<input type="checkbox"/>	<input type="checkbox"/>	<input type="checkbox"/>	<input type="checkbox"/>	<input type="checkbox"/>	<input type="checkbox"/>	<input type="checkbox"/>	<input type="checkbox"/>	<input type="checkbox"/>	<input type="checkbox"/>	<input type="checkbox"/>	<input type="checkbox"/>	<input type="checkbox"/>	<input type="checkbox"/>	<input type="checkbox"/>
607 n	<input type="checkbox"/>	<input type="checkbox"/>	<input type="checkbox"/>	<input checked="" type="checkbox"/>	<input checked="" type="checkbox"/>	<input checked="" type="checkbox"/>	<input type="checkbox"/>	<input type="checkbox"/>	<input type="checkbox"/>	<input type="checkbox"/>	<input type="checkbox"/>	<input type="checkbox"/>	<input type="checkbox"/>	<input type="checkbox"/>	<input type="checkbox"/>	<input type="checkbox"/>
22 10/10	<input type="checkbox"/>	<input type="checkbox"/>	<input type="checkbox"/>	<input type="checkbox"/>	<input type="checkbox"/>	<input type="checkbox"/>	<input type="checkbox"/>	<input type="checkbox"/>	<input type="checkbox"/>	<input type="checkbox"/>	<input type="checkbox"/>	<input type="checkbox"/>	<input type="checkbox"/>	<input type="checkbox"/>	<input type="checkbox"/>	<input type="checkbox"/>
23	<input type="checkbox"/>	<input type="checkbox"/>	<input type="checkbox"/>	<input checked="" type="checkbox"/>	<input checked="" type="checkbox"/>	<input checked="" type="checkbox"/>	<input type="checkbox"/>	<input type="checkbox"/>	<input type="checkbox"/>	<input type="checkbox"/>	<input type="checkbox"/>	<input type="checkbox"/>	<input type="checkbox"/>	<input type="checkbox"/>	<input type="checkbox"/>	<input type="checkbox"/>
24 ¹⁾	<input type="checkbox"/>	<input type="checkbox"/>	<input type="checkbox"/>	<input checked="" type="checkbox"/>	<input checked="" type="checkbox"/>	<input checked="" type="checkbox"/>	<input type="checkbox"/>	<input type="checkbox"/>	<input type="checkbox"/>	<input type="checkbox"/>	<input type="checkbox"/>	<input type="checkbox"/>	<input type="checkbox"/>	<input type="checkbox"/>	<input type="checkbox"/>	<input type="checkbox"/>
25	<input type="checkbox"/>	<input type="checkbox"/>	<input type="checkbox"/>	<input checked="" type="checkbox"/>	<input checked="" type="checkbox"/>	<input checked="" type="checkbox"/>	<input type="checkbox"/>	<input type="checkbox"/>	<input type="checkbox"/>	<input type="checkbox"/>	<input type="checkbox"/>	<input type="checkbox"/>	<input type="checkbox"/>	<input type="checkbox"/>	<input type="checkbox"/>	<input type="checkbox"/>
43	<input type="checkbox"/>	<input type="checkbox"/>	<input type="checkbox"/>	<input type="checkbox"/>	<input type="checkbox"/>	<input type="checkbox"/>	<input type="checkbox"/>	<input type="checkbox"/>	<input type="checkbox"/>	<input type="checkbox"/>	<input type="checkbox"/>	<input type="checkbox"/>	<input type="checkbox"/>	<input type="checkbox"/>	<input type="checkbox"/>	<input type="checkbox"/>

x = Section interlocks do not match.

¹⁾ The same applies to section variants of the same name.

These details only apply to once-only section replacement.
Always consult us if sections in continuous walls are to be regularly replaced.

3.5.1

Available sections, terms of delivery

Fitting HOESCH sections together

The section finger	Fits in the section socket															Fits in the corner section			
	1105	1205	1255	1605	1655	1705	1755	1805	2305	2405	2505	2555	2605	3406	3506		3606	3706	3806
1105	■	■	■	x	x	x	x	x	x	x	x	x	x	x	x	x	x	x	■
1205 ¹⁾	■	■	■	x	x	x	x	x	x	x	x	x	x	x	x	x	x	x	■
1255	■	■	■	x	x	x	x	x	x	x	x	x	x	x	x	x	x	x	■
1605	■	■	■	■	■	■	■	■	■	■	■	■	■	x	x	x	x	x	■
1655	■	■	■	■	■	■	■	■	■	■	■	■	■	x	x	x	x	x	■
1705 ¹⁾	■	■	■	■	■	■	■	■	■	■	■	■	■	x	x	x	x	x	■
1755 ¹⁾	■	■	■	■	■	■	■	■	■	■	■	■	■	x	x	x	x	x	■
1805	■	■	■	■	■	■	■	■	■	■	■	■	■	x	x	x	x	x	■
2305	■	■	■	x	x	x	x	x	■	■	■	■	■	x	x	x	x	x	■
2405	■	■	■	x	x	x	x	x	■	■	■	■	■	x	x	x	x	x	■
2505	■	■	■	x	x	x	x	x	■	■	■	■	■	x	x	x	x	x	■
2555 ¹⁾	■	■	■	x	x	x	x	x	■	■	■	■	■	x	x	x	x	x	■
2605	■	■	■	x	x	x	x	x	■	■	■	■	■	x	x	x	x	x	■

x = Section interlocks do not match.

¹⁾ The same applies to section variants of the same name.

These details only apply to once-only section replacement.

Always consult us if sections in continuous walls are to be regularly replaced.

Available sections, terms of delivery

Fitting HOESCH sections together

The section socket	Fits over the section finger															Fits in the corner section			
	1105	1205	1255	1605	1655	1705	1755	1805	2305	2405	2505	2555	2605	3406	3506		3606	3706	3806
1105	☑	☑	☑	☑	☑	☑	☑	☑	☑	☑	☑	☑	☑	x	x	x	x	x	☑
1205 ¹⁾	☑	☑	☑	☑	☑	☑	☑	☑	☑	☑	☑	☑	☑	x	x	x	x	x	☑
1255	☑	☑	x	☑	☑	☑	☑	☑	☑	☑	☑	☑	☑	x	x	x	x	x	☑
1605	x	x	x	☑	☑	☑	☑	☑	x	x	x	x	x	x	x	x	x	x	☑
1655	x	x	x	☑	☑	☑	☑	☑	x	x	x	x	x	x	x	x	x	x	☑
1705 ¹⁾	x	x	x	☑	☑	☑	☑	☑	x	x	x	x	x	x	x	x	x	x	☑
1755 ¹⁾	x	x	x	☑	☑	☑	☑	☑	x	x	x	x	x	x	x	x	x	x	☑
1805	x	x	x	☑	☑	☑	☑	☑	x	x	x	x	x	x	x	x	x	x	☑
2305	x	x	x	☑	☑	☑	☑	☑	☑	☑	☑	☑	☑	x	x	x	x	x	☑
2405	x	x	x	☑	☑	☑	☑	☑	☑	☑	☑	☑	☑	x	x	x	x	x	☑
2505	x	x	x	☑	☑	☑	☑	☑	☑	☑	☑	☑	☑	x	x	x	x	x	☑
2555 ¹⁾	x	x	x	☑	☑	☑	☑	☑	☑	☑	☑	☑	☑	x	x	x	x	x	☑
2605	x	x	x	☑	☑	☑	☑	☑	☑	☑	☑	☑	☑	x	x	x	x	x	☑



x = Section interlocks do not match.

¹⁾ The same applies to section variants of the same name.

These details only apply to once-only section replacement.
Always consult us if sections in continuous walls are to be regularly replaced.

Fitting UNION straight-web sections together

The interlocks of all UNION straight-web sections match.